

外啮合齿轮泵
AZPT



AZPT-...

定量泵
 $V = 20 \dots 36 \text{ cm}^3/\text{rev}$



目录

目录	
概述	
产品概况	
订货代码：单级泵	
订货代码：组合泵	
传动轴	
前盖	
管路油口	
齿轮泵，带集成式控制阀	
泵的设计计算	
性能曲线	
噪音曲线	
规格	
传动系的布置	
组合齿轮泵	
尺寸	
配件	
维修零部件	
调试注意事项	
配件	
订货代码	

特点

页号	
2	- 公称压力 250 bar
3	- 采用滑动轴承，适合重负荷应用
4	- 传动轴符合 ISO 或 SAE 要求
5	- 可以实现多台泵的组合
6	- 管路油口： 采用连接法兰或内螺纹
6	- 通过降低噪音和系统中的激振环节，
7	实现了最优的压力脉动
8	- 确保一贯的高质量
8	- 由于传动轴和泵壳得到了强化，因而显著延长了
9	泵的使用寿命
11	
12	
13	
15	
16	
18	
19	
20	
21	
22	

概述

外啮合设备的重要任务，是将机械能（转矩和转速）转变成液压能（流量和压力）；而外啮合齿轮马达则正好相反。这些设备必须具有较高的效率，以避免产生不必要的热量。这种高效率，是通过精密生产工艺和压力敏感型间隙密封而实现的。

而且，在这款低噪音的静音泵之中，这种双齿面原理有助于降低流量脉动，最多可降低75%。

排量方法

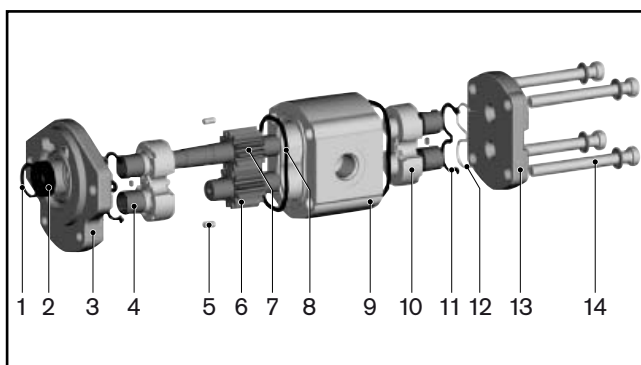
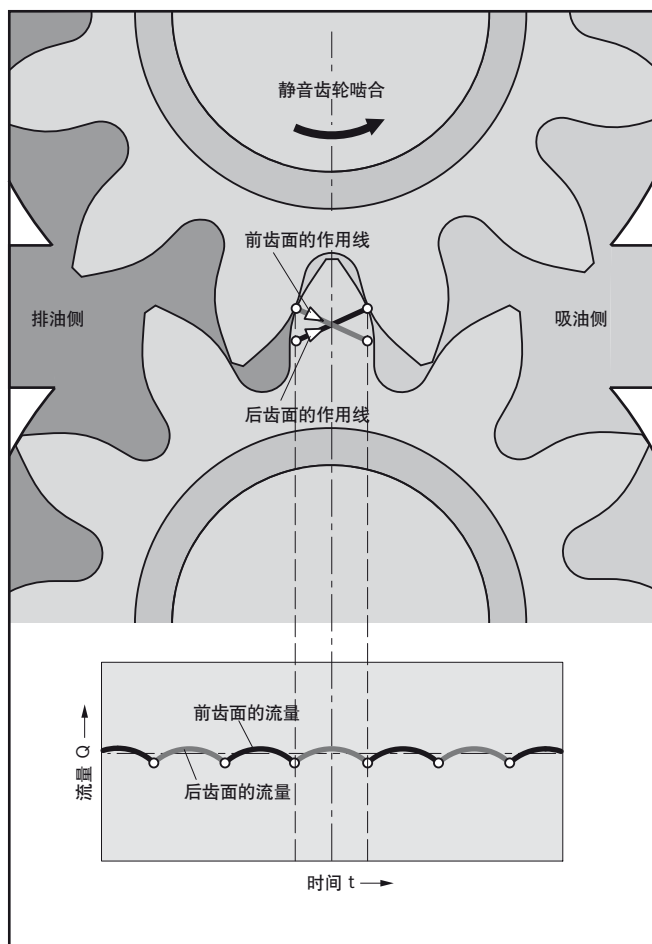
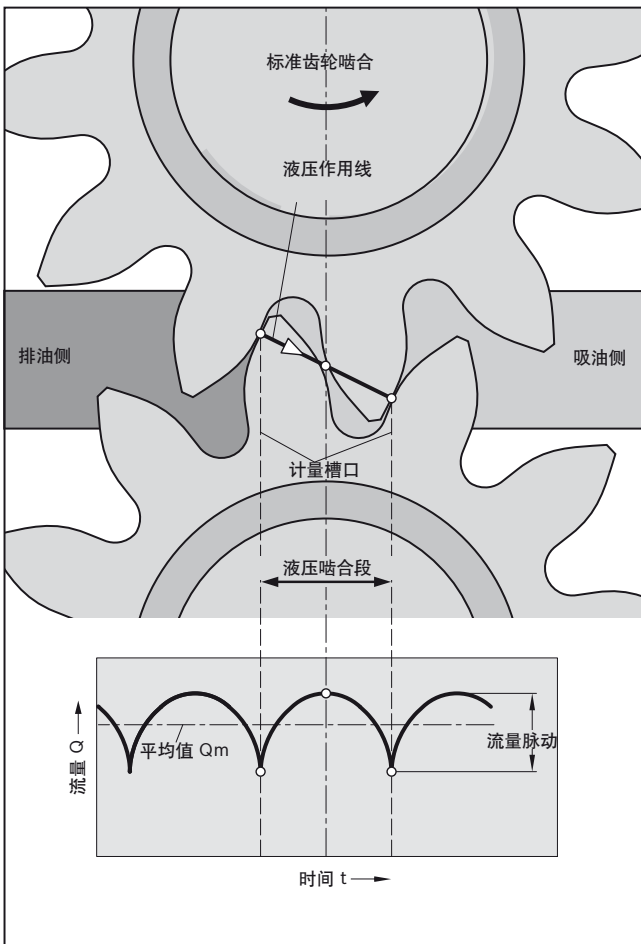

排量齿轮副的密闭区域，与传动轴的旋转方式相配合，从而形成了左图的流量特性曲线（示意性）。在标准型液压泵中，成对的齿轮每啮合一次，在这条特性曲线上就会脉动一次。在采用双齿面结构之后，这种静音泵的流量脉动降低了75%——相应地也降低了下游系统元件上的流量脉动——新的频率等于基础频率的两倍。在这个过程中，齿轮副呈现了一个更小的后齿面齿隙，因而提供液压密封的不仅有被动齿轮的前齿面，而且还包括后齿面。通过这种方式，前、后齿面交替地产生液流排放。而且，通过调节计量槽口的形状，就可以将液压作用线扩展为标准型液压泵的一半。

- | | |
|----------|------------|
| 1 固定环 | 8 泵壳密封件 |
| 2 轴密封圈 | 9 泵壳 |
| 3 前盖 | 10 轴承 |
| 4 滑动轴承 | 11 轴向区域密封件 |
| 5 定心销 | 12 支架 |
| 6 齿轮 | 13 端盖 |
| 7 齿轮（摩擦） | 14 固定螺钉 |

结构

这款外啮合齿轮泵，主要由支撑在轴承衬套或轴承（取决于不同的系列）上的一对齿轮、以及配备前盖和后盖的泵壳组成。传动轴从泵的前盖向外伸出，并通过轴密封圈加以密封。轴承上的这些支撑力，则由专用的轴承衬套所吸收；由于滑动轴承具有足够的弹性力，因而形成了面接触、而不是线接触的方式。由于这样，因而还确保了泵的出色耐磨性——尤其是在低速运行时。这对齿轮分别有12个齿，从而可保持齿轮泵产生最低限度的流量脉动和噪音。

内部密封是通过补偿力实现的，这些力与输出压力成正比。利用这种补偿方式，就能确保实现最优的效率。这些轴承为间隙（也即介于输送高压油液的轮齿之间）的末端提供密封功能。通过对轴承衬套的后部输入工作压力，就可以控制介于轮齿与轴承之间的密封区域。这些专用密封件，构成了这一区域的边界。对于轮齿顶部的这些径向间隙，则通过将齿轮推向泵壳的内部作用力而实现密封。

齿轮泵的轴向补偿

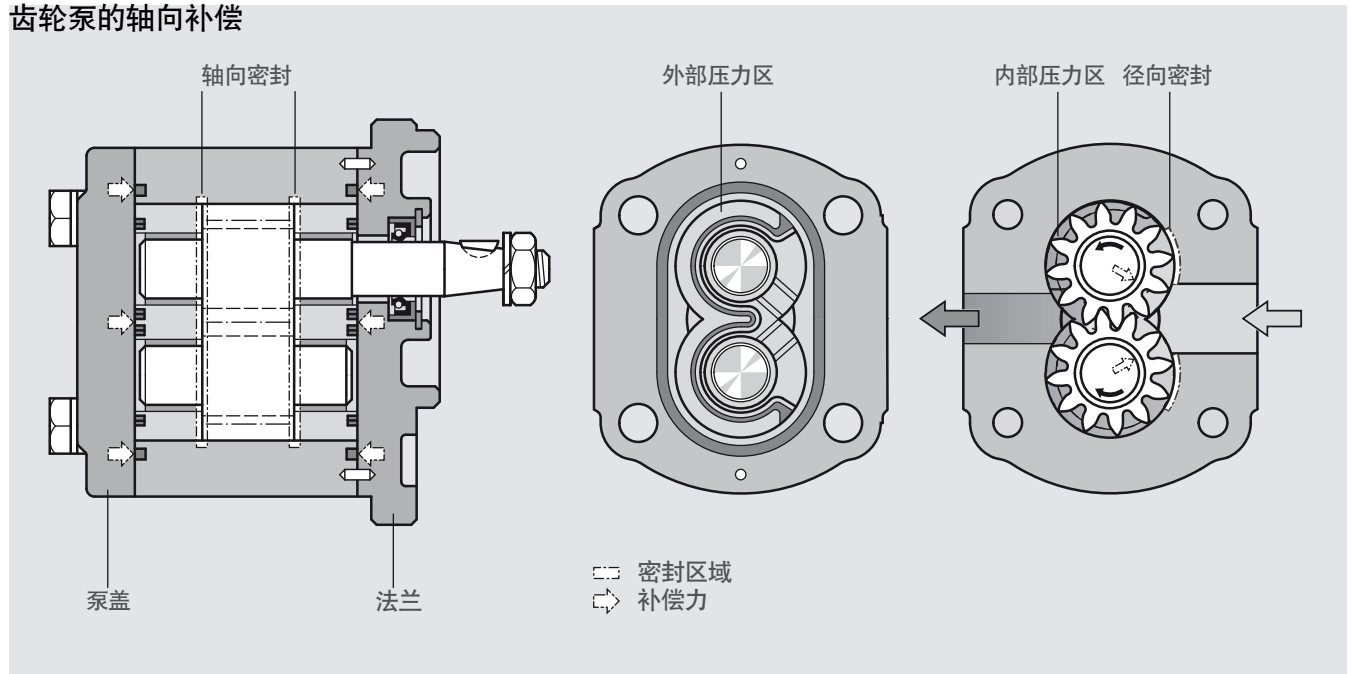



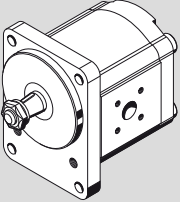

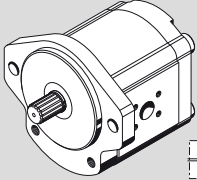







"T 系列" 标准型齿轮泵概览

型式	页号
	16

型式	页号
	18

订货代码

























外啮合设备, 单级泵, "静音" 型

AZ	P	T	-	x	x	-	020	R	C	B	20	M	B	18009	S xxxx																																																																																																																																																																																																																																																																														
<table border="1"> <tr> <td>功能</td> <td></td> <td></td> <td></td> <td></td> <td></td> <td></td> <td></td> <td></td> <td></td> <td></td> <td></td> <td></td> <td></td> <td></td> <td>特殊设计</td> </tr> <tr> <td>P = 泵</td> <td></td> <td></td> <td></td> <td></td> <td></td> <td></td> <td></td> <td></td> <td></td> <td></td> <td></td> <td></td> <td></td> <td></td> <td></td> </tr> <tr> <td>系列</td> <td></td> <td></td> <td></td> <td></td> <td></td> <td></td> <td></td> <td></td> <td></td> <td></td> <td></td> <td></td> <td></td> <td></td> <td></td> </tr> <tr> <td>2 = 泵壳宽度 110 mm</td> <td></td> <td></td> <td></td> <td></td> <td></td> <td></td> <td></td> <td></td> <td></td> <td></td> <td></td> <td></td> <td></td> <td></td> <td></td> </tr> <tr> <td>型式</td> <td></td> <td></td> <td></td> <td></td> <td></td> <td></td> <td></td> <td></td> <td></td> <td></td> <td></td> <td></td> <td></td> <td></td> <td></td> </tr> <tr> <td>2 = 经铬酸盐处理, 销轴连接</td> <td></td> <td></td> <td></td> <td></td> <td></td> <td></td> <td></td> <td></td> <td></td> <td></td> <td></td> <td></td> <td></td> <td></td> <td></td> </tr> <tr> <td>泵的大小, T 系列</td> <td></td> <td></td> <td></td> <td></td> <td></td> <td></td> <td></td> <td></td> <td></td> <td></td> <td></td> <td></td> <td></td> <td></td> <td></td> </tr> <tr> <td>020 = 20.0 cm³/rev</td> <td></td> <td></td> <td></td> <td></td> <td></td> <td></td> <td></td> <td></td> <td></td> <td></td> <td></td> <td></td> <td></td> <td></td> <td></td> </tr> <tr> <td>022 = 22.5 cm³/rev</td> <td></td> <td></td> <td></td> <td></td> <td></td> <td></td> <td></td> <td></td> <td></td> <td></td> <td></td> <td></td> <td></td> <td></td> <td></td> </tr> <tr> <td>025 = 25.0 cm³/rev</td> <td></td> <td></td> <td></td> <td></td> <td></td> <td></td> <td></td> <td></td> <td></td> <td></td> <td></td> <td></td> <td></td> <td></td> <td></td> </tr> <tr> <td>028 = 28.0 cm³/rev</td> <td></td> <td></td> <td></td> <td></td> <td></td> <td></td> <td></td> <td></td> <td></td> <td></td> <td></td> <td></td> <td></td> <td></td> <td></td> </tr> <tr> <td>032 = 32.0 cm³/rev</td> <td></td> <td></td> <td></td> <td></td> <td></td> <td></td> <td></td> <td></td> <td></td> <td></td> <td></td> <td></td> <td></td> <td></td> <td></td> </tr> <tr> <td>036 = 36.0 cm³/rev</td> <td></td> <td></td> <td></td> <td></td> <td></td> <td></td> <td></td> <td></td> <td></td> <td></td> <td></td> <td></td> <td></td> <td></td> <td></td> </tr> <tr> <td>旋转方向</td> <td></td> <td></td> <td></td> <td></td> <td></td> <td></td> <td></td> <td></td> <td></td> <td></td> <td></td> <td></td> <td></td> <td></td> <td></td> </tr> <tr> <td>R = 顺时针</td> <td></td> <td></td> <td></td> <td></td> <td></td> <td></td> <td></td> <td></td> <td></td> <td></td> <td></td> <td></td> <td></td> <td></td> <td></td> </tr> <tr> <td>L = 逆时针</td> <td></td> <td></td> <td></td> <td></td> <td></td> <td></td> <td></td> <td></td> <td></td> <td></td> <td></td> <td></td> <td></td> <td></td> <td></td> </tr> </table>															功能															特殊设计	P = 泵																系列																2 = 泵壳宽度 110 mm																型式																2 = 经铬酸盐处理, 销轴连接																泵的大小, T 系列																020 = 20.0 cm ³ /rev																022 = 22.5 cm ³ /rev																025 = 25.0 cm ³ /rev																028 = 28.0 cm ³ /rev																032 = 32.0 cm ³ /rev																036 = 36.0 cm ³ /rev																旋转方向																R = 顺时针																L = 逆时针																														
功能															特殊设计																																																																																																																																																																																																																																																																														
P = 泵																																																																																																																																																																																																																																																																																													
系列																																																																																																																																																																																																																																																																																													
2 = 泵壳宽度 110 mm																																																																																																																																																																																																																																																																																													
型式																																																																																																																																																																																																																																																																																													
2 = 经铬酸盐处理, 销轴连接																																																																																																																																																																																																																																																																																													
泵的大小, T 系列																																																																																																																																																																																																																																																																																													
020 = 20.0 cm ³ /rev																																																																																																																																																																																																																																																																																													
022 = 22.5 cm ³ /rev																																																																																																																																																																																																																																																																																													
025 = 25.0 cm ³ /rev																																																																																																																																																																																																																																																																																													
028 = 28.0 cm ³ /rev																																																																																																																																																																																																																																																																																													
032 = 32.0 cm ³ /rev																																																																																																																																																																																																																																																																																													
036 = 36.0 cm ³ /rev																																																																																																																																																																																																																																																																																													
旋转方向																																																																																																																																																																																																																																																																																													
R = 顺时针																																																																																																																																																																																																																																																																																													
L = 逆时针																																																																																																																																																																																																																																																																																													
<table border="1"> <tr> <td colspan="5">阀的调节</td> <td></td> <td></td> <td></td> <td></td> <td></td> <td></td> <td></td> <td></td> <td></td> <td></td> <td></td> </tr> <tr> <td colspan="5">200 xx = PRV 200 bar</td> <td></td> <td></td> <td></td> <td></td> <td></td> <td></td> <td></td> <td></td> <td></td> <td></td> <td></td> <td></td> </tr> <tr> <td colspan="5">xxx 11 = FCV 11 l/min</td> <td></td> <td></td> <td></td> <td></td> <td></td> <td></td> <td></td> <td></td> <td></td> <td></td> <td></td> <td></td> </tr> <tr> <td colspan="5">18009 = PRV + FCV</td> <td></td> <td></td> <td></td> <td></td> <td></td> <td></td> <td></td> <td></td> <td></td> <td></td> <td></td> <td></td> </tr> <tr> <td colspan="5">180 bar, 9 l/min</td> <td></td> <td></td> <td></td> <td></td> <td></td> <td></td> <td></td> <td></td> <td></td> <td></td> <td></td> <td></td> </tr> <tr> <td colspan="5">后盖</td> <td></td> <td></td> <td></td> <td></td> <td></td> <td></td> <td></td> <td></td> <td></td> <td></td> <td></td> <td></td> </tr> <tr> <td colspan="5">B = 标准</td> <td></td> <td></td> <td></td> <td></td> <td></td> <td></td> <td></td> <td></td> <td></td> <td></td> <td></td> <td></td> </tr> <tr> <td colspan="5">E = FCV 外部残余流量</td> <td></td> <td></td> <td></td> <td></td> <td></td> <td></td> <td></td> <td></td> <td></td> <td></td> <td></td> <td></td> </tr> <tr> <td colspan="5">S = FCV 内部残余流量</td> <td></td> <td></td> <td></td> <td></td> <td></td> <td></td> <td></td> <td></td> <td></td> <td></td> <td></td> <td></td> </tr> <tr> <td colspan="5">V = PRV + FCV</td> <td></td> <td></td> <td></td> <td></td> <td></td> <td></td> <td></td> <td></td> <td></td> <td></td> <td></td> <td></td> </tr> <tr> <td colspan="5">密封件</td> <td></td> <td></td> <td></td> <td></td> <td></td> <td></td> <td></td> <td></td> <td></td> <td></td> <td></td> <td></td> </tr> <tr> <td colspan="5">M = NBR</td> <td></td> <td></td> <td></td> <td></td> <td></td> <td></td> <td></td> <td></td> <td></td> <td></td> <td></td> <td></td> </tr> <tr> <td colspan="5">K = NBR, 轴密封圈使用FKM</td> <td></td> <td></td> <td></td> <td></td> <td></td> <td></td> <td></td> <td></td> <td></td> <td></td> <td></td> <td></td> </tr> </table>															阀的调节																200 xx = PRV 200 bar																	xxx 11 = FCV 11 l/min																	18009 = PRV + FCV																	180 bar, 9 l/min																	后盖																	B = 标准																	E = FCV 外部残余流量																	S = FCV 内部残余流量																	V = PRV + FCV																	密封件																	M = NBR																	K = NBR, 轴密封圈使用FKM																																																																			
阀的调节																																																																																																																																																																																																																																																																																													
200 xx = PRV 200 bar																																																																																																																																																																																																																																																																																													
xxx 11 = FCV 11 l/min																																																																																																																																																																																																																																																																																													
18009 = PRV + FCV																																																																																																																																																																																																																																																																																													
180 bar, 9 l/min																																																																																																																																																																																																																																																																																													
后盖																																																																																																																																																																																																																																																																																													
B = 标准																																																																																																																																																																																																																																																																																													
E = FCV 外部残余流量																																																																																																																																																																																																																																																																																													
S = FCV 内部残余流量																																																																																																																																																																																																																																																																																													
V = PRV + FCV																																																																																																																																																																																																																																																																																													
密封件																																																																																																																																																																																																																																																																																													
M = NBR																																																																																																																																																																																																																																																																																													
K = NBR, 轴密封圈使用FKM																																																																																																																																																																																																																																																																																													
<table border="1"> <tr> <th>传动轴</th> <th>合适的前盖</th> <th>前盖</th> <th>管路油口</th> </tr> <tr> <td>C 锥形键槽轴 1:5</td> <td></td> <td>B 方形法兰 定心直径 Ø 100 mm</td> <td>07 方形法兰 SAE 公制螺纹</td> </tr> <tr> <td>N 两面卡钳</td> <td></td> <td>C SAE J 744 101-2 B 2-螺栓法兰 Ø 101.6 mm</td> <td>20 矩形法兰</td> </tr> <tr> <td>D 花键轴 SAE J 744 22-4 13T</td> <td></td> <td>M 2-螺栓安装 定心直径 Ø 52 mm 带有密封圈</td> <td></td> </tr> <tr> <td>P 花键轴 SAE J 744 19-4 11T</td> <td></td> <td></td> <td></td> </tr> </table>															传动轴	合适的前盖	前盖	管路油口	C 锥形键槽轴 1:5		B 方形法兰 定心直径 Ø 100 mm	07 方形法兰 SAE 公制螺纹	N 两面卡钳		C SAE J 744 101-2 B 2-螺栓法兰 Ø 101.6 mm	20 矩形法兰	D 花键轴 SAE J 744 22-4 13T		M 2-螺栓安装 定心直径 Ø 52 mm 带有密封圈		P 花键轴 SAE J 744 19-4 11T																																																																																																																																																																																																																																																														
传动轴	合适的前盖	前盖	管路油口																																																																																																																																																																																																																																																																																										
C 锥形键槽轴 1:5		B 方形法兰 定心直径 Ø 100 mm	07 方形法兰 SAE 公制螺纹																																																																																																																																																																																																																																																																																										
N 两面卡钳		C SAE J 744 101-2 B 2-螺栓法兰 Ø 101.6 mm	20 矩形法兰																																																																																																																																																																																																																																																																																										
D 花键轴 SAE J 744 22-4 13T		M 2-螺栓安装 定心直径 Ø 52 mm 带有密封圈																																																																																																																																																																																																																																																																																											
P 花键轴 SAE J 744 19-4 11T																																																																																																																																																																																																																																																																																													

注意：并非所有的变型产品，都可以通过订货代码来加以选择！

订货代码

外啮合设备, 组合泵, “静音”型

AZ	P	TTSS	-	x	x	-	032/022/016/005	R	C	B	20	20	20	20	K	B
<p>功能 P = 泵</p> <p>系列 B = 1.0...7.1 cm³/rev S = 4.0...28 cm³/rev F = 4.0...28 cm³/rev T = 20.0...36 cm³/rev N = 20.0...36 cm³/rev U = 22.5...63 cm³/rev G = 22.5...63 cm³/rev</p> <p>系列, 与泵的截面 1 有关</p> <p>2 = 泵壳宽度 110 mm</p> <p>型式, 与泵的截面 1 有关</p> <p>2 = 经铬酸盐处理, 销轴连接</p> <p>泵的大小 对应于每一个系列</p> <p>旋转方向 R = 顺时针 L = 逆时针</p>							<p>后盖 与最后一个泵的截面相关</p> <p>B = 标准</p> <p>密封件 M = NBR K = NBR, 轴密封圈使用FKM 与泵截面 1 相关的轴密封</p>									
<p>传动轴 对应于泵的部件 1</p>							<p>前盖 对应于泵的部件 1</p>				<p>管路油口 泵的每一个部件</p>					
<p>B 系列 : 合适的前盖</p> <p>H 锥形键槽轴, 1:8  O</p>							<p>O 方形法兰 定心直径 Ø 25.38 mm</p>				<p>02 公制螺纹 DIN 3852 T1 </p>					
<p>F 系列, S 系列 :</p> <p>C 锥形键槽轴, 1:5  B</p> <p>H 锥形键槽轴, 1:8  O</p> <p>R 花键轴 SAE J 744 16-4 9T  R</p>							<p>B 方形法兰 定心直径 Ø 80 mm </p> <p>O 方形法兰 定心直径 Ø 36.47 mm </p> <p>R SAE J 744 82-2 A 定心直径 Ø 82.55 mm 2-螺栓安装 </p>				<p>20 矩形法兰 </p>					
<p>N 系列, T 系列 :</p> <p>C 锥形键槽轴, 1:5  B</p> <p>D 花键轴 SAE SAE J 744 22-4 13T  C</p> <p>N 两面卡钳  M</p>							<p>B 方形法兰 定心直径 Ø 100 mm </p> <p>C SAE J 744 101-2 B 定心直径 Ø 101.6 mm 2-螺栓安装 </p> <p>M 定心直径 带有密封圈 </p>				<p>07 方形法兰 SAE 公制螺纹 </p> <p>20 矩形法兰 </p>					
<p>G 系列, U 系列 :</p> <p>C 锥形键槽轴, 1:5  B</p> <p>D 花键轴 SAE J 744 22-4 13T  C</p> <p>H 锥形键槽轴, 1:8  O</p>							<p>B 方形法兰 定心直径 Ø 105 mm </p> <p>C SAE J 744 101-2 B Centering Ø 101.6 mm 2-螺栓安装 </p> <p>O 方形法兰 定心直径 Ø 50.78 mm </p>				<p>07 方形法兰 SAE 公制螺纹 </p> <p>20 矩形法兰 </p>					

注意：并非所有的变型产品，都可以通过订货代码来加以选择！

传动轴

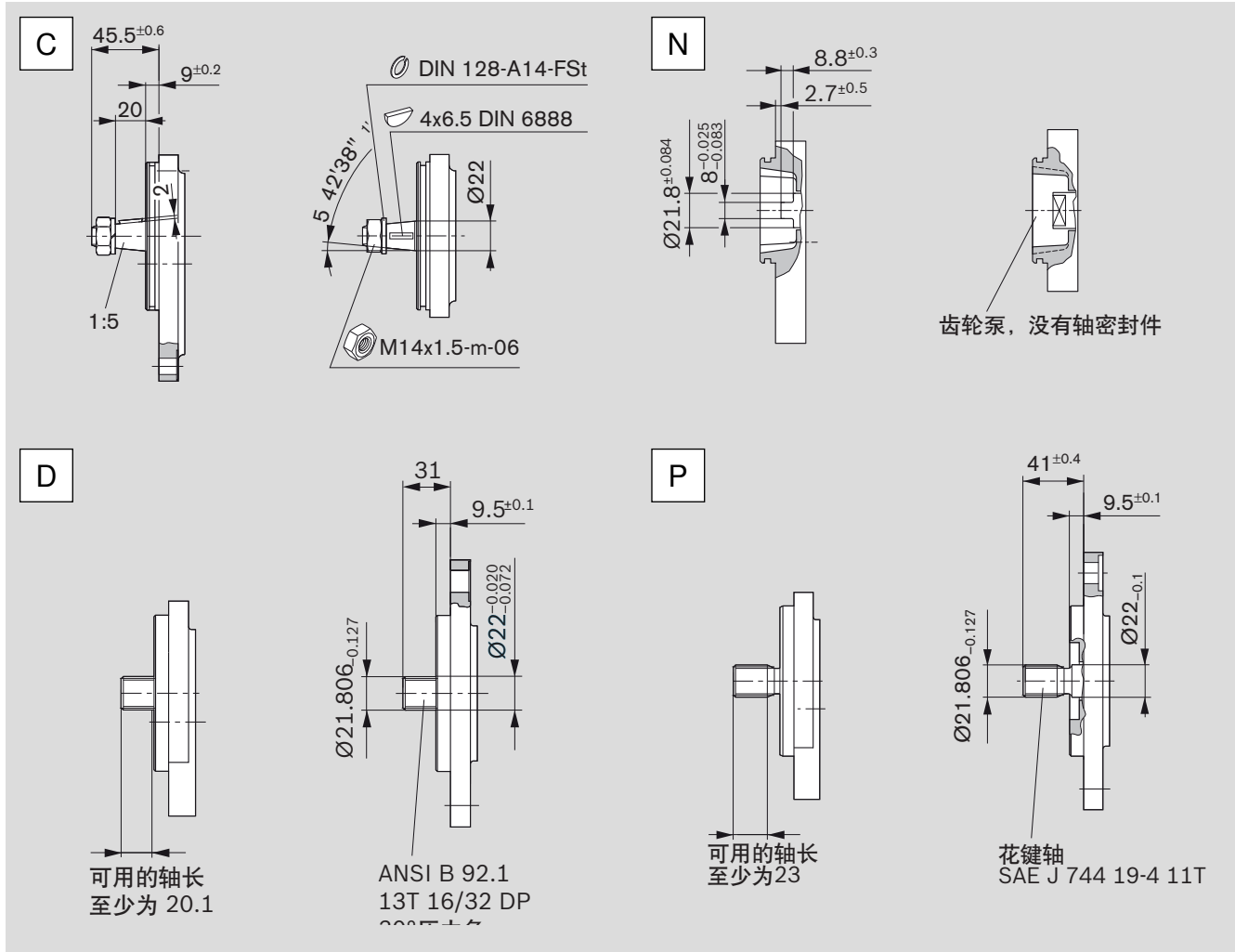

前盖

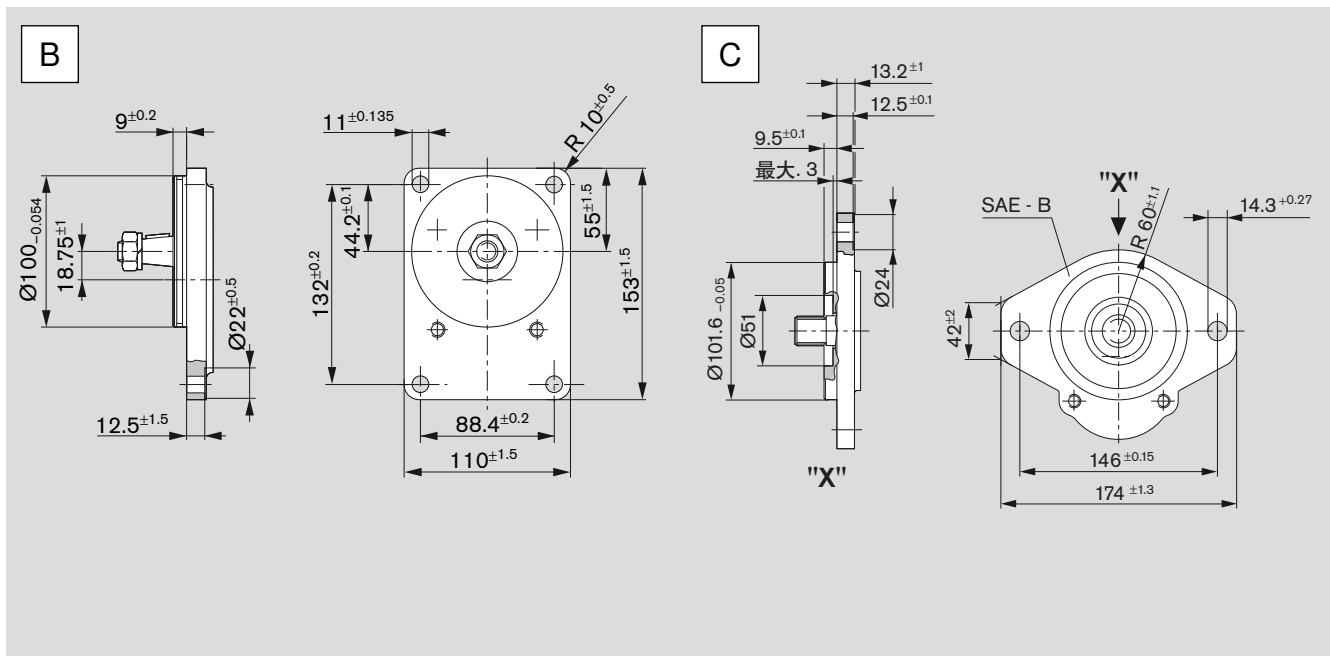

前盖 (续)

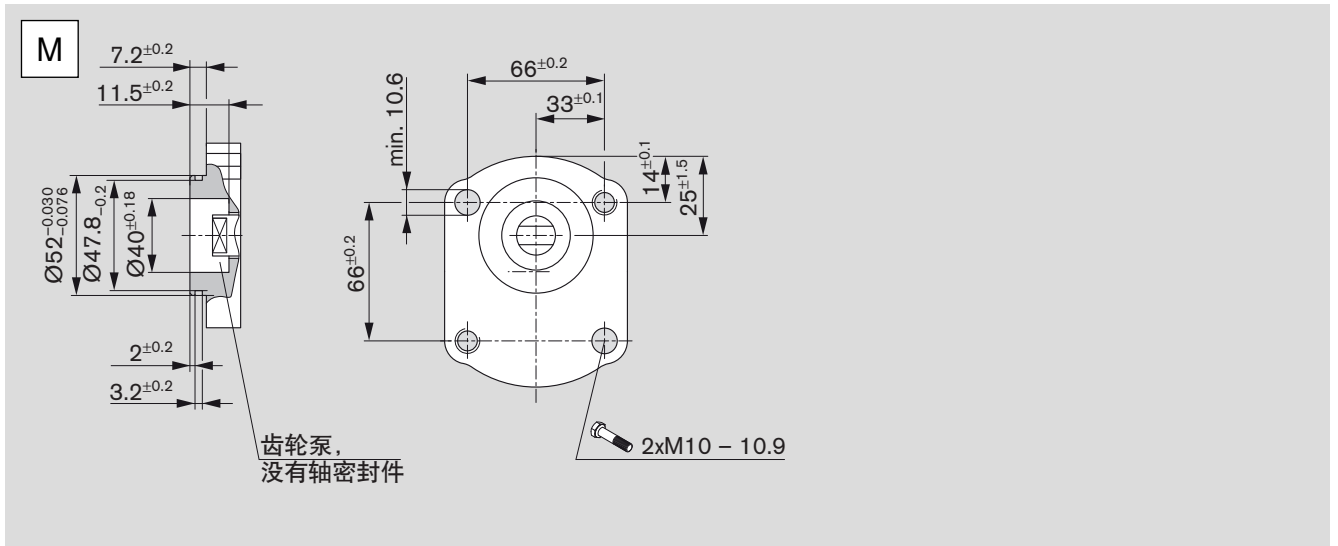

管路油口

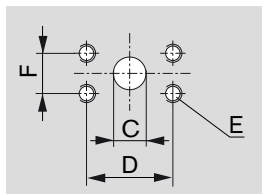

07 方形法兰 SAE, 公制螺纹

订货代码	泵的大小	压力侧				吸油侧			
		C	D	E	F	C	D	E	F
07	20 cm ³	18	47.6	M 10	22.2	25	47.6	M 10	22.2
	22.5...36 cm ³			深度 14			52.4	深度 14	26.2

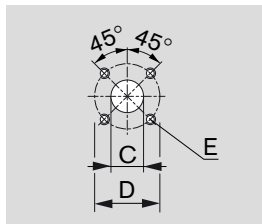

20 矩形法兰

订货代码	泵的大小	压力侧			吸油侧		
		C	D	E	C	D	E
20	20...36 cm ³	18	55	M8 depth 13	26	55	M8 depth 13

齿轮泵， 带集成式控制阀

为减少外部管路，可以将流量控制阀或溢流阀组合到齿轮泵的泵盖之中。这种结构的典型应用，就是动力转向系统中的液压供油。齿轮泵输出恒定的流量，并与驱动转速无关。多余的流量既可经内部油路回到吸油口，也通过外部管道输送给其它设备。

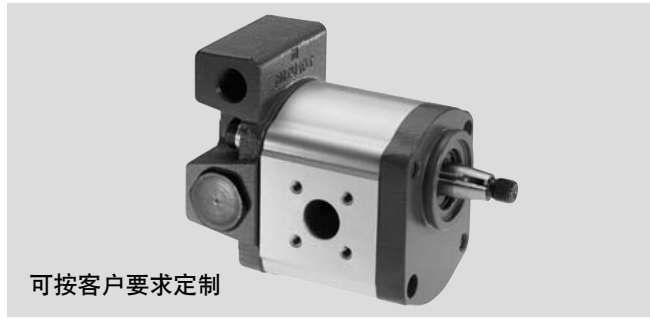

可按客户要求定制

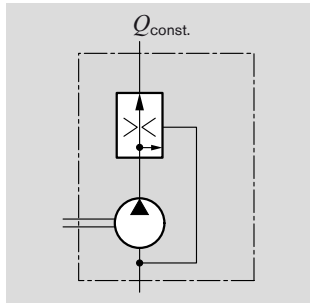

三通流量控制阀
多余的流量回到吸油管路

$Q_{\text{常量}} = 2...30 \text{ l/min}$

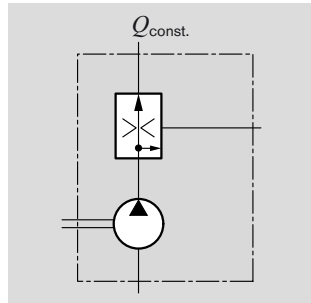

三通流量控制阀
过剩的流量经外部排出；可承载

$Q_{\text{常量}} = 2...30 \text{ l/min}$

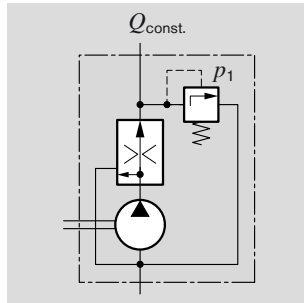

三通流量控制阀，带有溢流阀
多余的流量回到吸油管路

$Q_{\text{常量}} = 2...30 \text{ l/min}$
 $p_1 = 100...180 \text{ bar}$

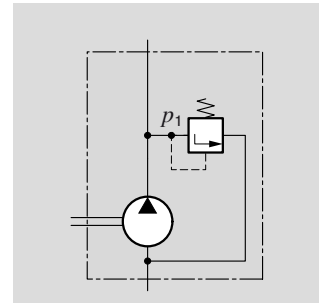

溢流阀
排出的油液回到吸油管路

$p_1 = 5...250 \text{ bar}$

订货代码

S	xxx17
---	-------

E	xxx12
---	-------

V	15011
---	-------

泵的设计计算

泵的设计计算依据以下参数：

- V [cm³/rev] 排量
- Q [l/min] 流量
- p [bar] 压力
- M [Nm] 驱动扭矩
- n [rev/min] 驱动转速
- P [kW] 驱动功率

此外，还需要计算各种不同的效率值，比如：

- η_v 容积效率
- η_{hm} 液压-机械效率
- η_t 总效率

通过这些公式，描述了各种不同变量之间的关系。

其中还包含一些换算系数，以便将这些参数转变为实际情况下经常遇到的一些数据单位。

提醒：关于选择近似数据时常用的一些曲线，可参见以下各页。

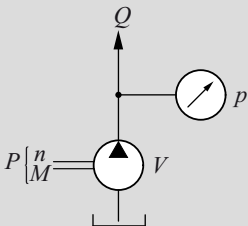

$$Q = V \cdot n \cdot \eta_v \cdot 10^{-5}$$

$$p = \frac{M \cdot \eta_{hm}}{1.59 \cdot V}$$

$$P = \frac{p \cdot Q}{6 \cdot \eta_t}$$

$$V = \frac{Q}{n \cdot \eta_v} \cdot 10^5$$

$$V = \frac{M \cdot \eta_{hm}}{159 \cdot p}$$

$$Q = \frac{6 \cdot P \cdot \eta_t}{p}$$

$$n = \frac{Q}{V \cdot \eta_v} \cdot 10^5$$

$$M = \frac{1.59 \cdot V \cdot p}{\eta_{hm}}$$

$$p = \frac{6 \cdot P \cdot \eta_t}{Q}$$

[%]

n — η_v —→ Q V [cm³/rev] Q [l/min] p [bar] 提醒： η [%] e.g. 95 [%]

M — η_{hm} —→ p

P — η_t —→ p · Q n [rev/min] P [kW] M [Nm]

性能曲线

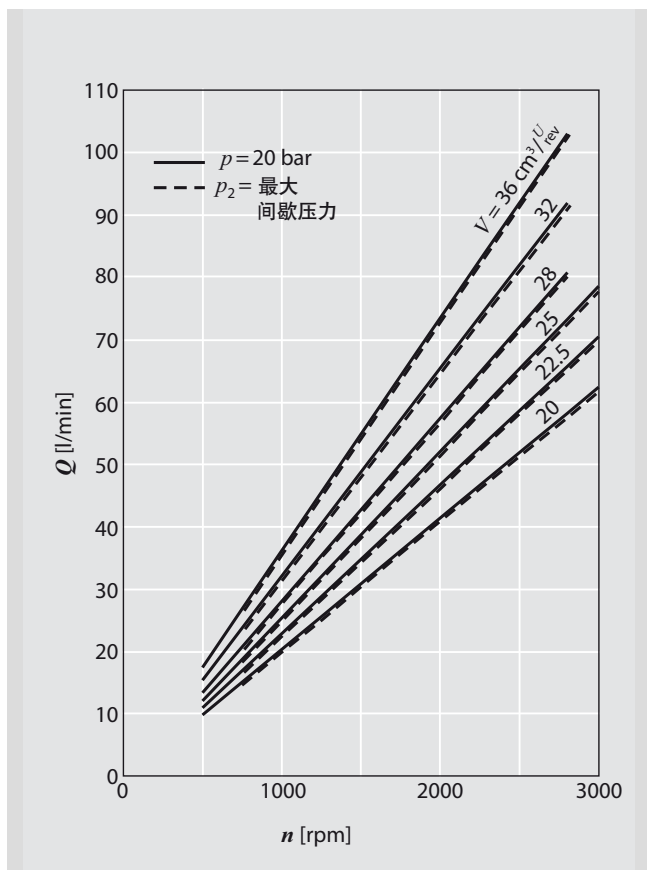

$v = 35 \text{ mm}^2/\text{s}, \vartheta = 50 \text{ }^\circ\text{C}$

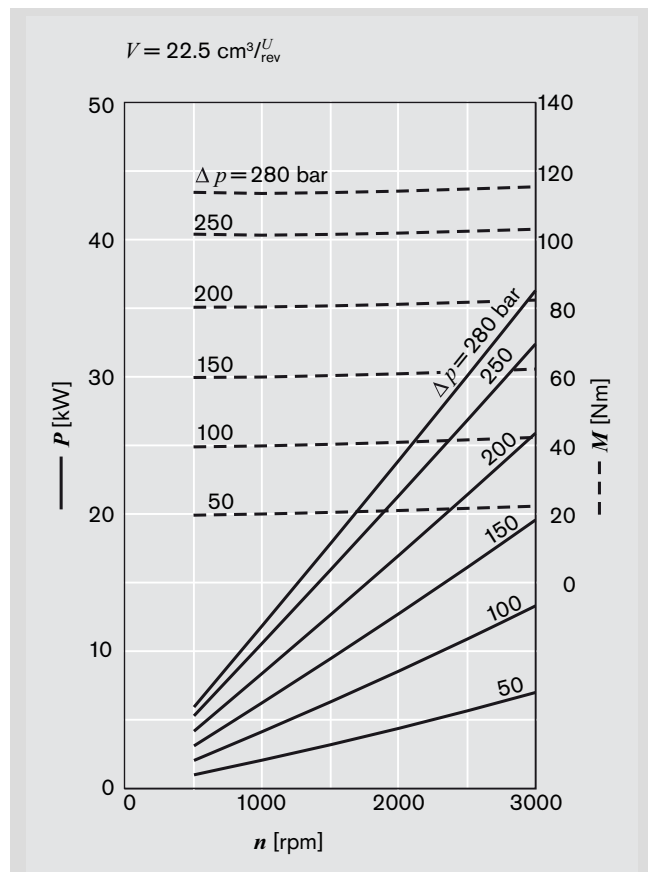
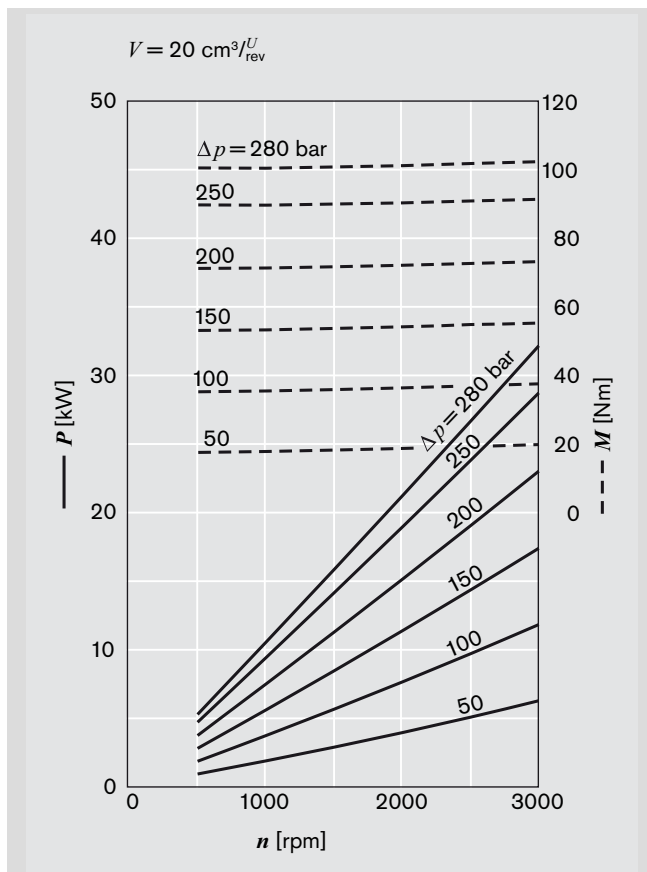

性能曲线 (续)

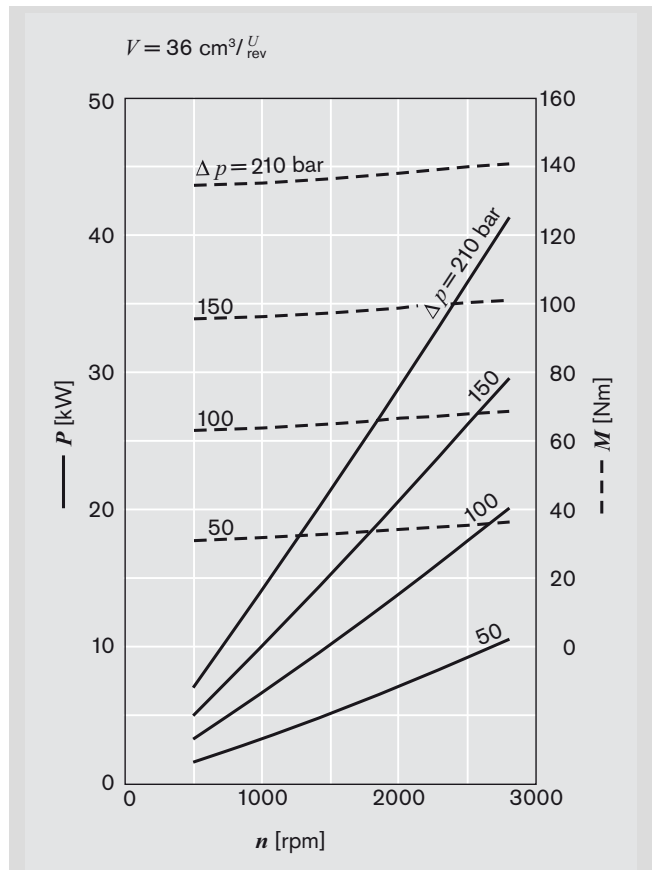
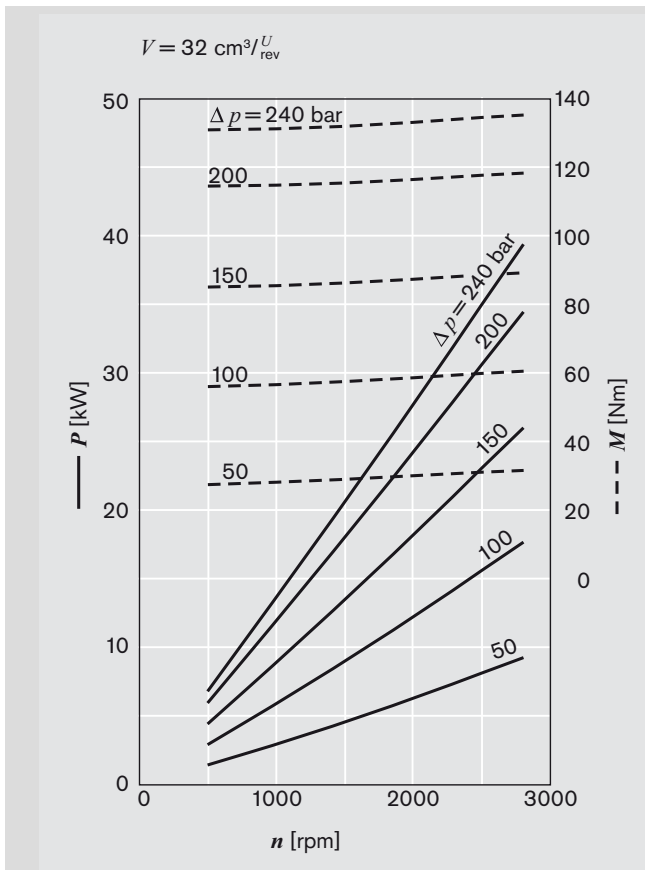
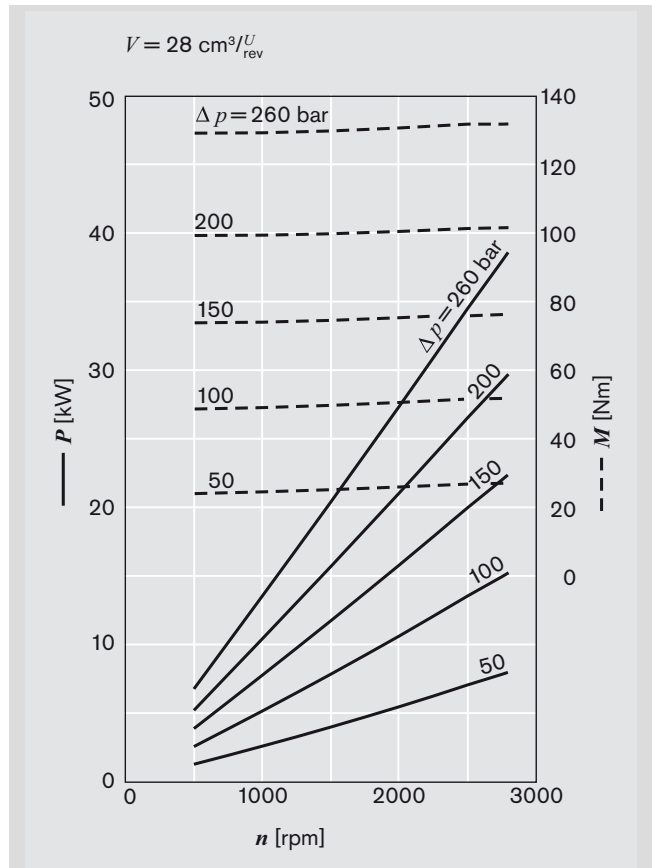
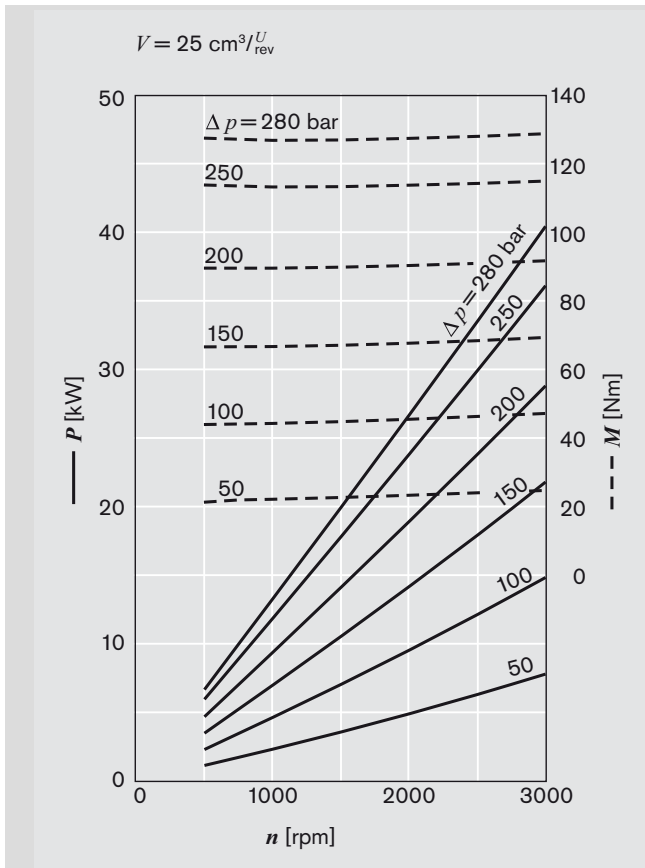

噪音曲线

噪音等级取决于转速和压力范围；这个压力范围介于10 bar和压力值 p_2 （参见第 12 页的规格表）之间。

油液数据： $v = 32 \text{ mm}^2/\text{s}$, $\vartheta = 50 \text{ }^\circ\text{C}$ 。

对于从吸声测量室测得的噪音值进行计算而得到的声音压力等级，符合 DIN 45635 第 26 章的要求。

这些都是相关型号液压泵的典型特性值。

它们描述了由液压泵单独发出的空气载声。

这里，并没有考虑环境方面的影响（安装现场，管道布置，以及其它系统元件）。

这里的每一个数值，分别针对一台单级液压泵。

测量传感器与液压泵之间的距离：1 米。

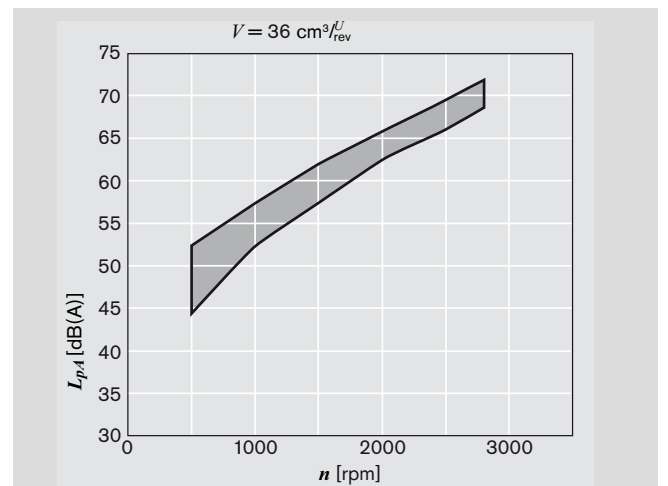
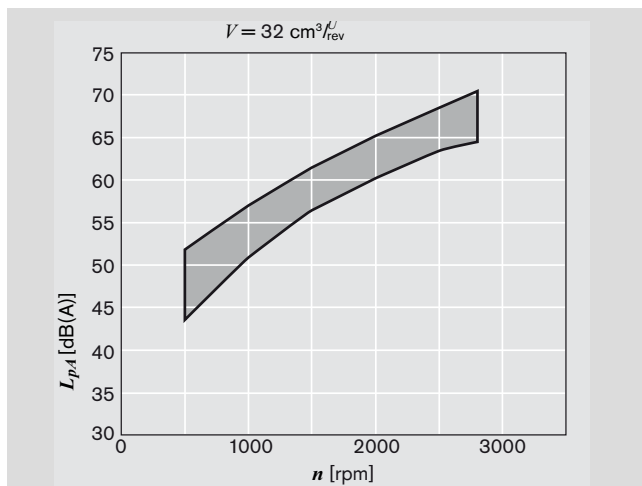
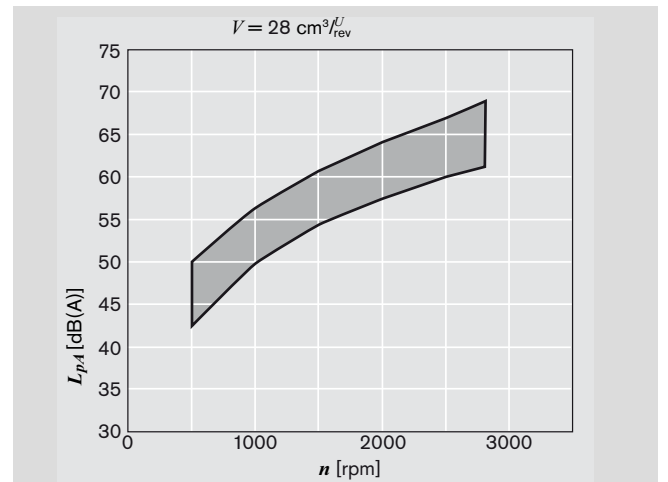
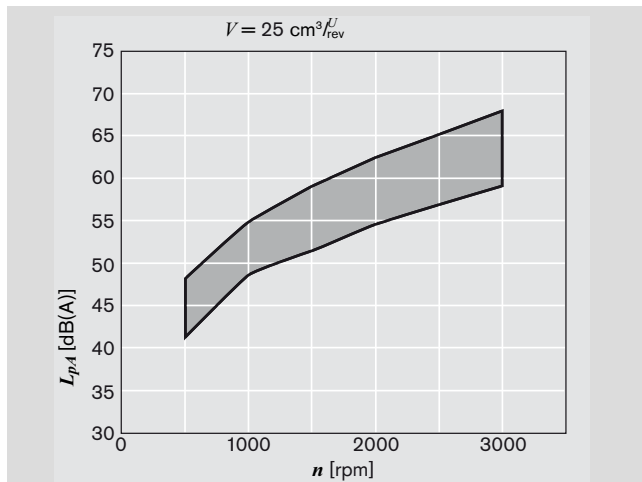
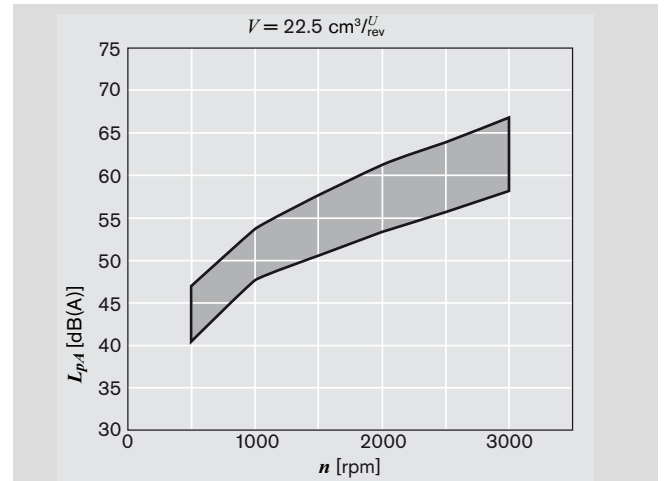
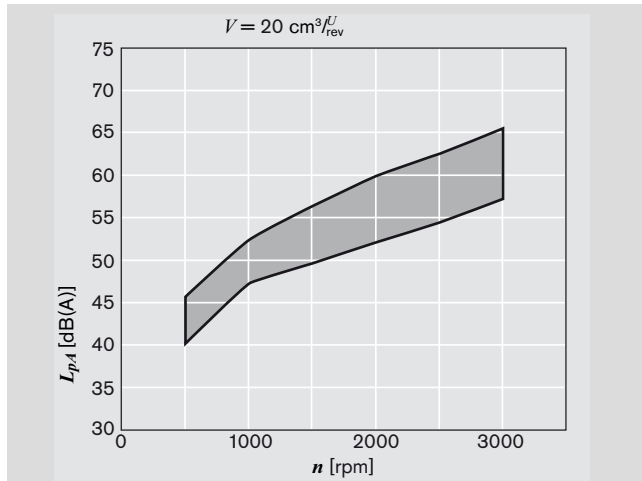

规格

概述	
结构	外啮合齿轮泵
安装	法兰或带有套管的贯穿螺栓
管路油口	法兰
旋转方向 (从轴的视点看)	顺时针或逆时针, 只能以图示的旋转方向驱动这台液压泵
安装位置	任何部位
轴上的负载	径向和轴向力, 待咨询后确定
环境温度范围	- 30 °C...+80 °C, 使用 NBR 密封件 - 20 °C...+110 °C, 使用 FKM 密封件
液压油	- 矿物油应当符合 DIN 51 524, 1-3 ; 然而在更高的负载条件下, 至少应采用符合推荐的DIN 51 524 章节 2 的HLP 液压流体 ; - 符合RE 07075 - 经过咨询, 可以采用其它的工作流体
粘度	12...800 mm ² /s, 允许的范围 20...100 mm ² /s, 推荐的范围 ...2000 mm ² /s, 泵的起动所允许的范围
液压油温度范围	-30 °C...+80 °C -20 °C...+110 °C, 使用 FKM 密封件
过滤 *)	洁净度等级至少达到20/18/15, 符合 ISO 4406 (1999)

*) NBR = Perbunan®
**) FKM = Viton®
***) 在使用具有重要反向功能的控制系统或装置 (比如转向与制动阀)时, 所选定的油液过滤类型必须与这些装置或系统的灵敏度相适应。

必须切实遵循整套系统相关联的安全性要求。

如果应用系统需要实现数量很多的负载周期, 则请咨询我们的技术部门。

旋转方向的定义

始终以传动轴的视点观察。

提醒：在尺寸图纸上, 总是显示顺时针转向的液压泵。对于逆时针旋转的液压泵, 其传动轴的位置、以及吸油口和压力油口的位置都不相同。

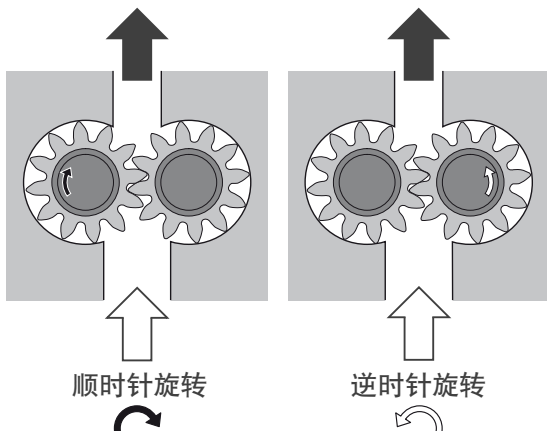

压力的定义

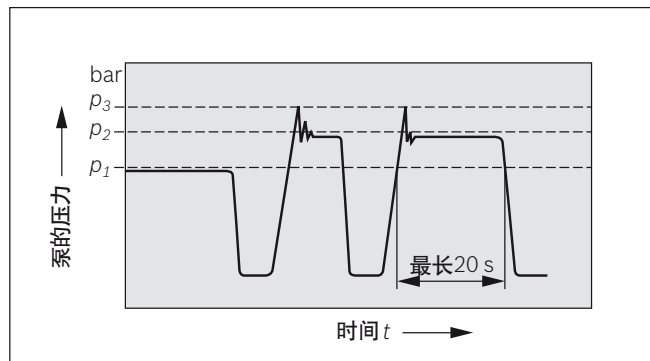

p_1 最高连续压力
 p_2 最高间歇压力
 p_3 最高峰值压力

AZPT-2x

排量	V	cm ³ /rev	20	22,5	25	28	32	36
吸油压力	p_e		0.7...3 (absolute), with tandem pumps $p_e (p_2) = \max. 0.5 p_e (p_1)$					
最高连续压力	p_1	bar	250	250	250	230	210	180
最高间歇压力	p_2		280	280	280	260	240	210
最高峰值压力	p_3		300	300	300	280	260	230
在以下压力时的最低转速	< 100	rpm	500	500	500	500	500	500
12 mm ² /s	100...180		600	600	600	600	600	600
180... p_2			800	800	800	800	800	800
25 mm ² /s	p_2		500	500	500	500	500	500
在以下压力时的最高转速	p_2		3000	3000	3000	2800	2800	2800

传动系的布置1. 弹性联轴器

在这种轴联接方式下，不得向液压泵传递任何径向力或轴向力。

泵轴套管的最大径向跳动值为 0.2 mm。

参见联轴器厂商提供的安装操作规程，以详细了解轴向最大许可的偏差。

2. 联轴套管

用于 DIN 或 SAE 花键轴上。

提醒：无论是在泵轴还是联轴套管上，都不得有径向或轴向力的作用。这种联轴套管在轴向必须能移动自如。泵轴与传动轴之间的距离，必须为 2^{+1} 。需要采用油浴或油雾润滑。

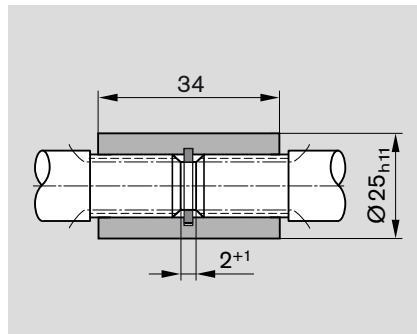
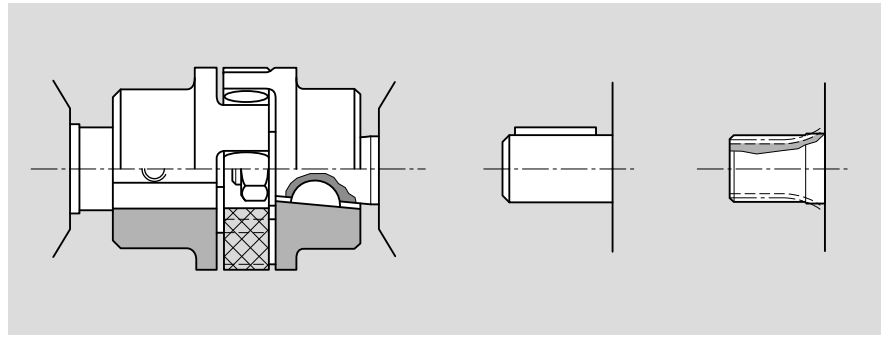

花键轴	订货代码	M _{最大} [Nm]
SAE-B 13 齿	D	320
SAE-C 11 齿	P	180

3. 带柄托的传动轴

通过这种传动轴，液压泵可以紧密联轴电机、或内燃机与齿轮减速器等。泵的传动轴有一个专用的柄托和驱动器[Ⓒ]（没有包含在供货内容中）。

这里，没有采用轴密封。

推荐的驱动端和密封件的布置与尺寸如下。

Ⓐ 传动轴

泵壳硬化钢 DIN 17 210,

比如 20 MnCrS 5

泵壳硬化层，深 1.0；HRA 83^{±2}

针对密封圈的接触面而进行了无膛线研磨，R_t # 4μm

Ⓑ 轴的径向密封

采用涂覆橡胶的密封件(参见 DIN 3760, AS 型；或采用双层唇缘密封圈)。

切削一个 15° 的斜角，或者在安装轴密封圈时使用护套。

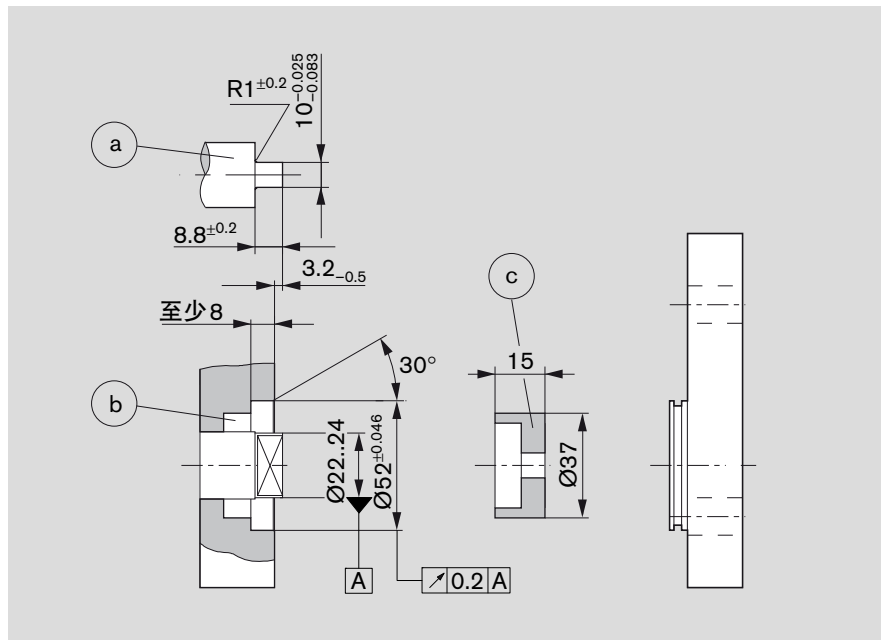

M _{最大} [Nm]	V [cm ³ /rev]	P _{最大} [bar]
95	20	270
	22.5	240
	25	220
	28	190
	32	170
	36	150

4. 不具外部轴承的 V 形皮带和直齿轮 或螺旋齿的齿轮驱动

请求使用 V 形皮带或齿轮传动时，
请提交该应用的详细信息（尤其是尺寸 a 、 d_m 、 d_w 和角度 α ），以便我们
日后评价。对于螺旋齿齿轮驱动，还需要螺旋角度 β 的详细信息。

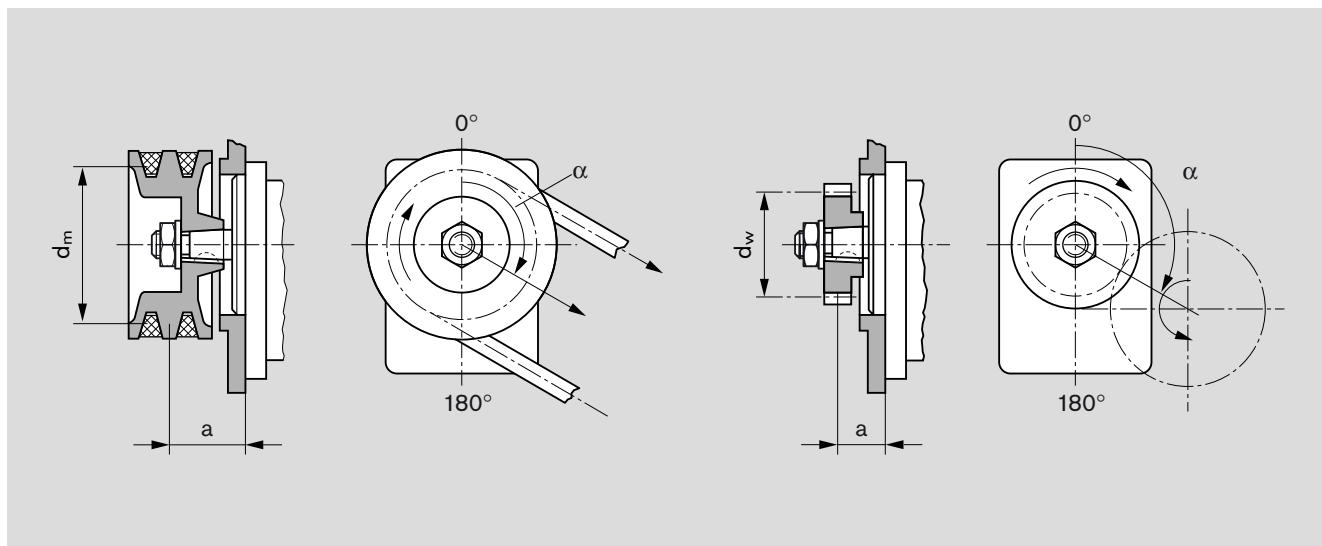

组合齿轮泵

这种齿轮泵非常适合多泵组合的布置方式，一级泵的传动轴延伸到二级泵、甚至三级泵；联轴器安装在每一对液压泵之间。

多数情况下，每一台泵与相邻泵都相互隔离，也即各自使用独立的吸油口。作为一种选项，还可以采用一个公用的吸油口。

提醒：基本上采用单级泵的规格，只是有以下这些限制：
 最大转速：应当由所使用液压泵中的最高额定转速来确定。
 压力：这些限制源于传动轴的强度、以及直接传动和驱动器等因素。相关的数据请参见标有尺寸的图纸。

标准型直接传动期间的压力限制

对于 N 系列和 T 系列的齿轮泵，二级泵送驱动器可传输的最大负载为 $M_{最大} = 95 \text{ Nm}$ ，也即对二级泵和更多级液压泵有着压力限制。

传动轴		可传输的最大驱动扭矩 * [Nm]
C	1:5	200
N	卡钳	95
D	SAE 13t	320
P	SAE 11t	180

* 只有符合上述条件时，这些数值才适用。

如果第一级通过柄托（驱动器）或 1 型外置轴承驱动，那么适用以下公式所述的压力限制。

对于更高的传输扭矩与/或旋转类振动，可以采用加强型直接传动。可按客户要求，定制专用的结构设计。

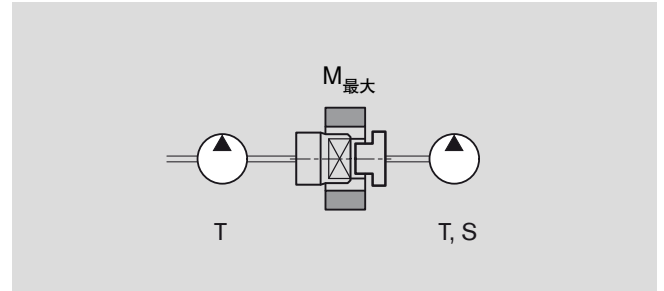

组合泵

系列泵 1	$M_{最大}$ [Nm]	系列泵 2
T	95	T
T	65	S

在配置组合泵时，我们建议把排量最大的泵放在驱动轴一侧。

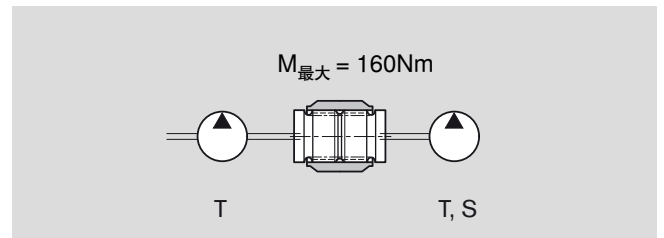

$$M_{最大} \geq \Delta p_1 \cdot V_1 \cdot 0.0177 + \Delta p_2 \cdot V_2 \cdot 0.0177 + \Delta p_3 \cdot V_3 \cdot 0.0177$$

Δp [bar] V [cm³/rev]

尺寸 标准范围

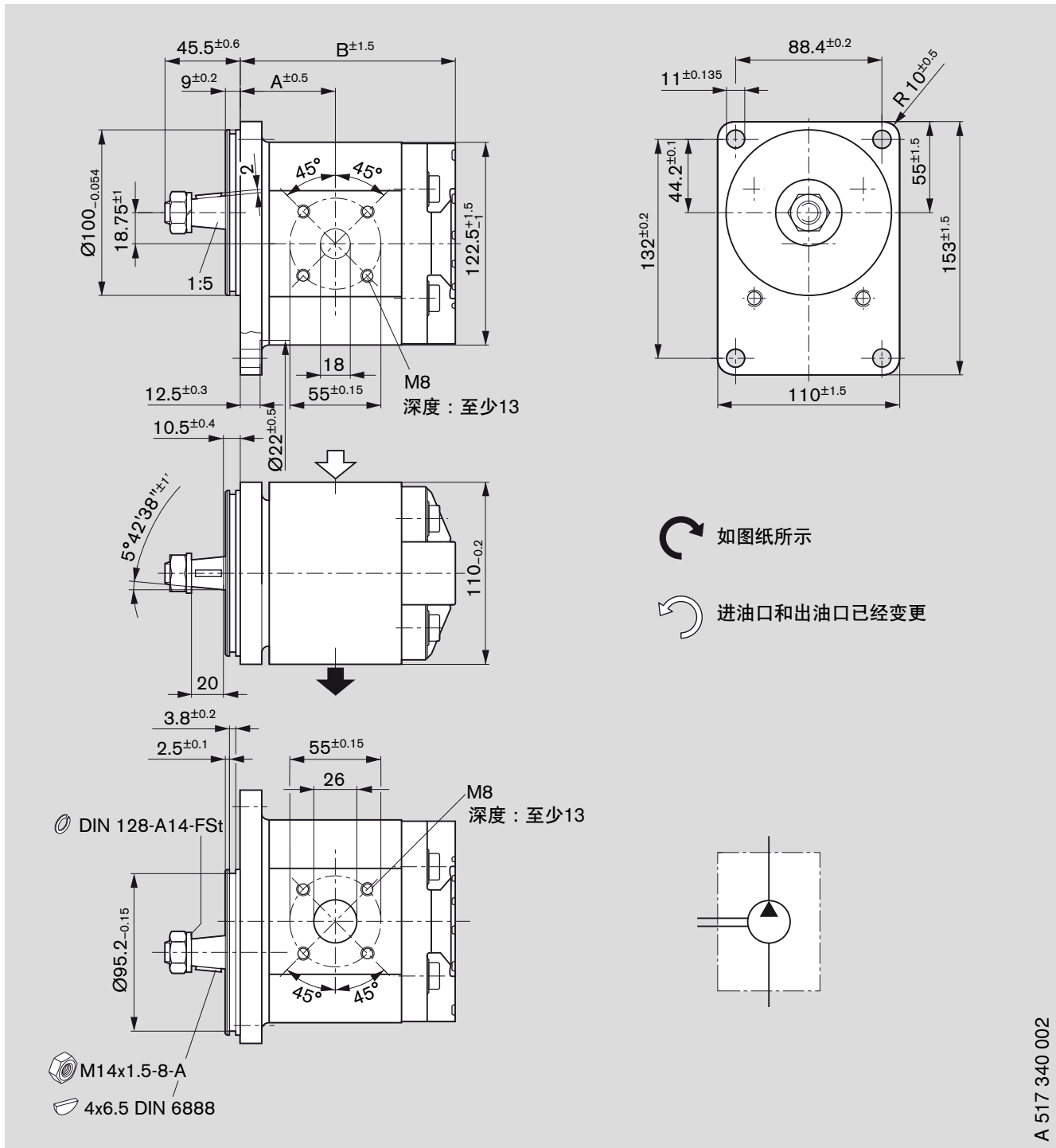

订货代码:

AZPT - 22 - □□□ □ CB 20 MB

排量 [cm ³ /rev]	订货代码		最高工作压力 [bar]	最高转速 [rpm]	重量 kg	尺寸 [mm]		M8, 深度13
	左	右				A	B	
20	0 517 625 309	0 517 625 008	280	3000		52.0	119.1	
22.5	0 510 725 302	0 517 725 016	280	3000		53.5	122.1	
25	0 517 725 313	0 517 725 017	280	3000		55.0	125.1	
28	0 517 725 314	0 517 725 018	260	3000		56.5	128.1	
32	0 517 725 315	0 517 725 019	240	2800		59.0	132.6	
36	0 517 725 316	0 517 725 020	210	2600		61.0	137.1	

尺寸 标准范围

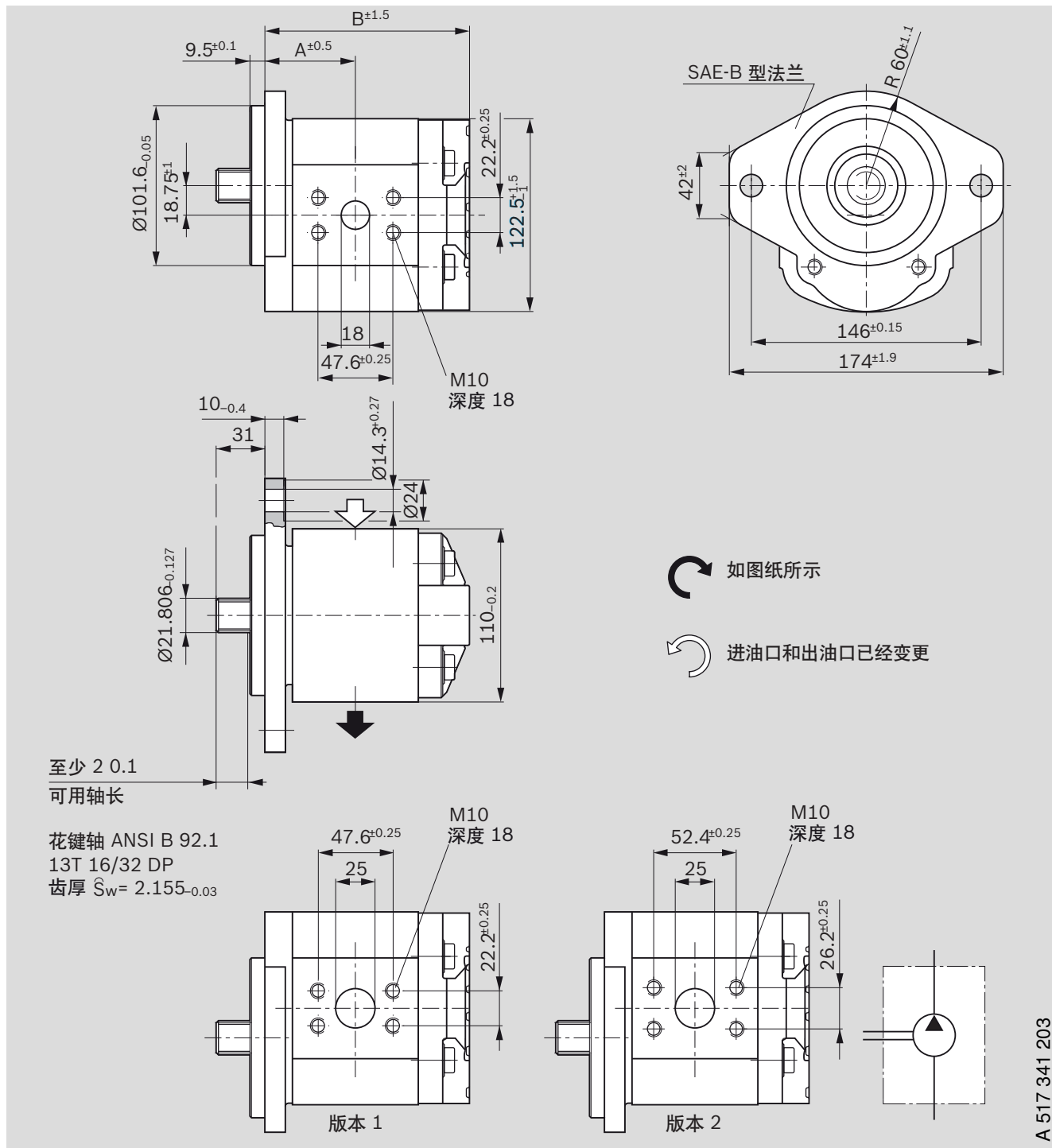

订货代码：
AZPT - 22 - □□□ □ DC 07 KB

排量 [cm ³ /rev]	订货代码		最高工作 压力 [bar]	最高转速 [rpm]	重量 kg	尺寸 [mm]				M10 18 深度	版本
	左	右				A	B	C	D		
20	0 517 625 310	0 517 625 009	280	3000		52.0	119.1	25	47.6	M10 18 深度	1
22.5	0 517 725 317	0 517 725 021	280	3000		53.0	122.1	25	52.4		2
25	0 517 725 318	0 517 725 022	280	3000		55.0	125.1	25	52.4		
28	0 517 725 319	0 517 725 023	260	3000		56.5	128.1	25	52.4		
32	0 517 725 320	0 517 725 024	240	2800		59.0	132.6	25	52.4		
36	0 517 725 321	0 517 725 025	210	2600		61.0	137.1	25	52.4		

配件

这些配件可用于矩形法兰 20，请参见第 7 页
齿轮泵的法兰，90°角

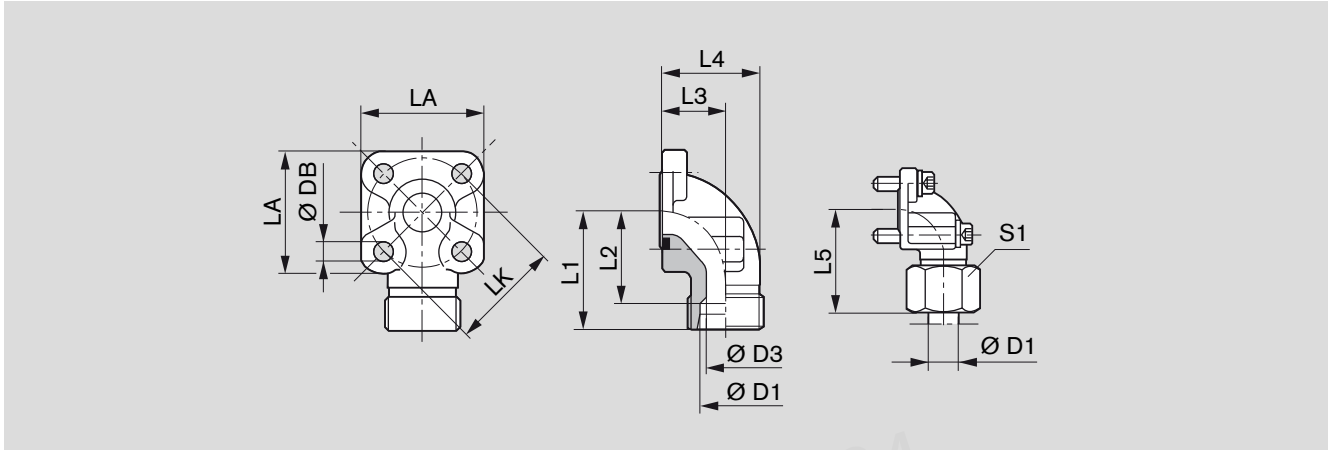

LK	D1	D3	L1	L2	L3	L4	L5	LA	S1	DB	螺栓		Seal ring	Mass kg	Part number	p (bar)
											2x	2x				
55	20S	17	45	34.5	24.0	40.0	56.0	58	36	8.4	M8x25	M8x50	33x2.5	0.44	1 515 702 004	250
55	30S	26	49	35.5	32.0	50.0	62.0	58	50	8.4	M8x25	M8x50	33x2.5	0.50	1 515 702 006	250
55	35L	31	49	38.5	32.0	51.5	62.0	58	50	8.4	M8x25	M8x60	32x2.5	0.47	1 515 702 005	100
55	42L	38	49	38.0	40.0	64.5	61.0	58	60	8.4	M8x25	M8x70	32x2.5	0.60	1 515 702 019	100

完整的配件，带有密封圈、公制螺栓套件、螺母和凸台。

备注

您可以在我们的下述出版物中，找到许可的紧固扭矩值：
"外啮合设备的一般操作说明" RC 07 012 - B1。

维修零部件

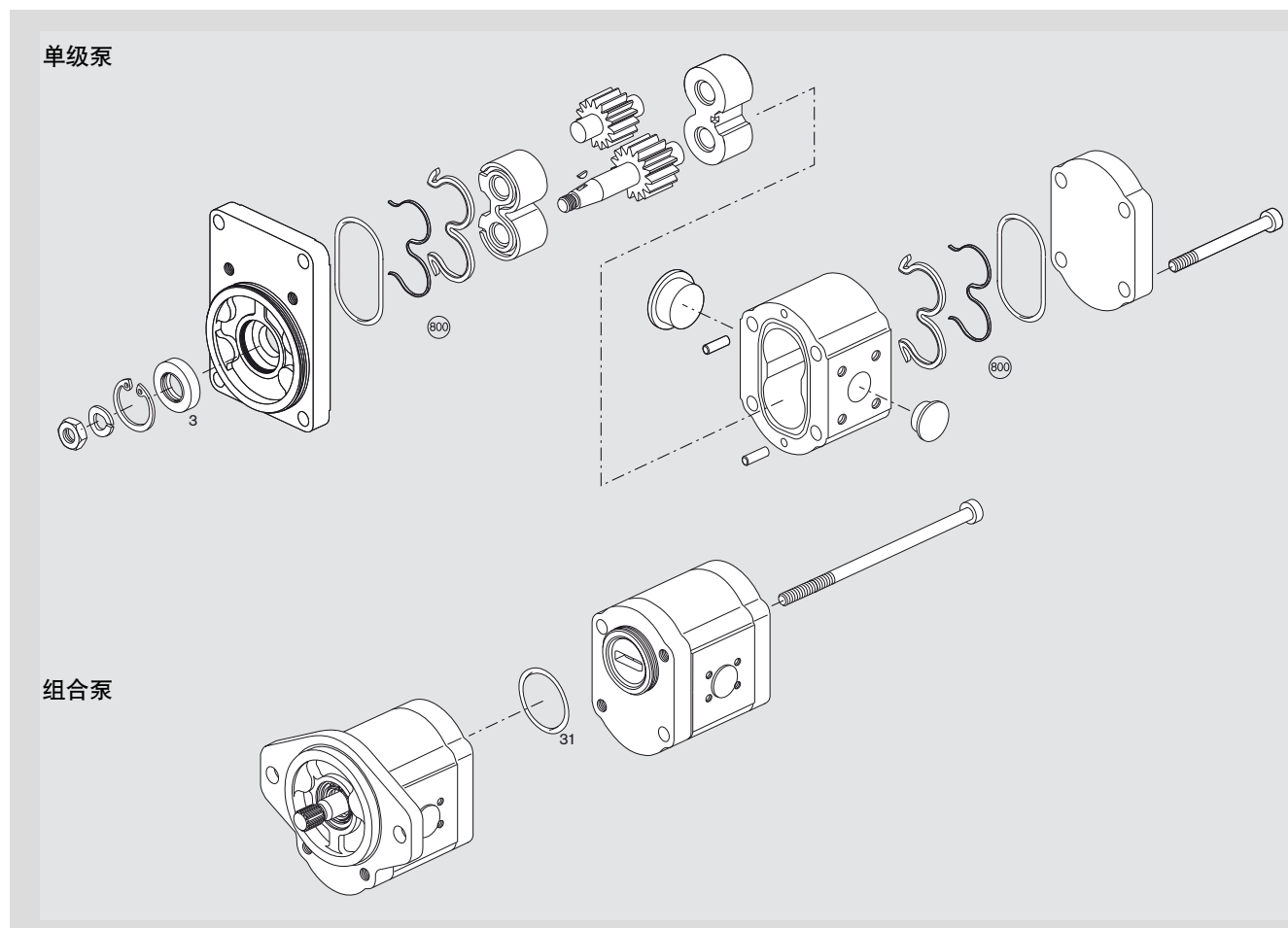

页号	订货代码	"T" 密封套件 位置 # 800 NBR	轴密封圈 位置 #3	尺寸	密封圈 位置 #3.1	材料	尺寸
16	AZPT - 22 - ... • C B 20 M B	1517010226	1510283023	40x22x7	-	NBR	
17	AZPT - 22 - ... • D C 20 K B	1517010226	1510283028	40x22x7	-	FKM (SSR)	

NBR = Perbunan® FKM = Viton®

调试注意事项

滤油方式建议

外啮合齿轮泵的大部分故障案例均由污染的液压油所导致。鉴于保修条款并不涵盖污染所造成的磨损，所以建议采用符合洁净度水平 20/18/15 ISO 4406 的过滤方式，从而在污染颗粒大小和浓度方面将污染降至容许的级别：

工作压力 [bar]	>160	<160
污染度等级 ISO 4406	18/15	19/16
需要达到的水平 $\beta_x = 75$	20	25

我们建议：应始终采用全流量滤油器。根据 ISO 4406 的要求，液压油的基本污染不得超出等级 20/18/15。过去的经验表明，新的油液往往都高于这一限值。在这种情况下，应使用带有专用滤油器的注油装置。

概述

- 在液压泵交货之前，我们已检查了相关的功能和性能。请勿擅自改动泵的任何部分，否则会造成保修条款失效！
- 泵的运行，必须符合许可的相关技术数据 (参见 15 到 18 页)。

项目规划注意事项

在“液压技术培训” 3 RE 00 281 的“项目规划注意事项和液压系统的设计”中，收录了完整的注意事项和建议。对于外啮合齿轮泵的用户，我们建议切实遵循以下事项。

技术数据

所有相关的技术数据都取决于生产公差，只在特定的边际条件下才有效。

请注意：由于上述原因，可能会产生一种散射效应；因此在某些边际条件下 (比如粘度)，这些技术数据可能会发生改变。

特性

在设计外啮合齿轮泵时，应根据 10 到 12 页中显示的产品特性，记下最大的可能维护数据。

关于正确使用博世力士乐液压产品的更多信息，请参见我们的文件：“液压产品的一般信息” RE 07 008。

交货时的相关资料

交货时会包含具有 20 到 58 页的订货代码和设备测量数据下所描述的特性的元件。

在我们出版的资料 RC07 012-B1“外啮合设备的一般操作说明”中，您可以找到更多内容。

SANPUM

为高端制造业提供一流的工业产品

SANPUM

深圳市三浦贸易有限公司

地址：深圳市南山区南海大道海王大厦A座19E

电话：86-755-23881000

传真：86-755-23881777

邮箱：info@sanpum.com



4008 824 824
WWW.SANPUM.COM